

MACDUFF SHIP DESIGN 90' FISHING VESSEL

PRINCIPAL DIMENSIONS

LENGTH O.A. (Hull)	29.100 m
LENGTH FISHING REG.	27.400 m (89' 11")
LENGTH LOAD LINE	27.170 m (89' 2")
LENGTH B.P.	26.150 m
BREADTH MLD.	10.300 m
DEPTH MLD.	5.000 m
COMPLIMENT	14 CREW

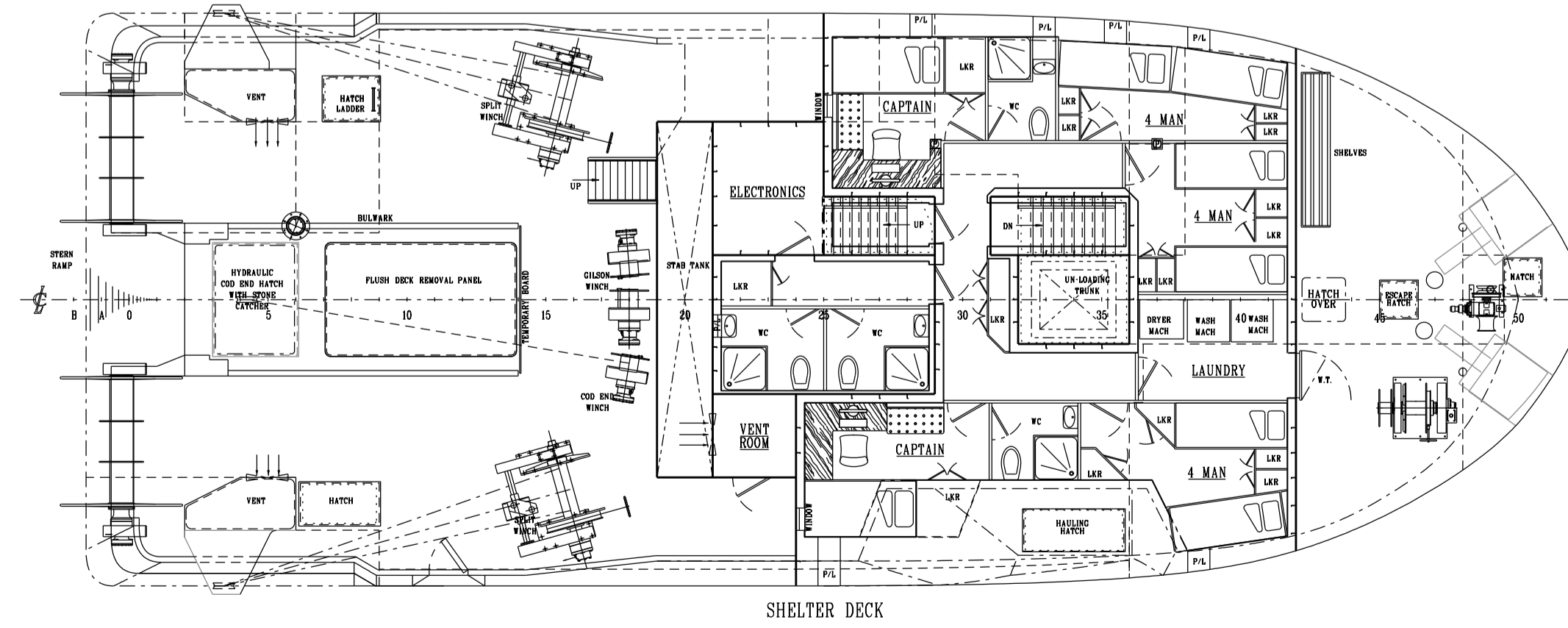
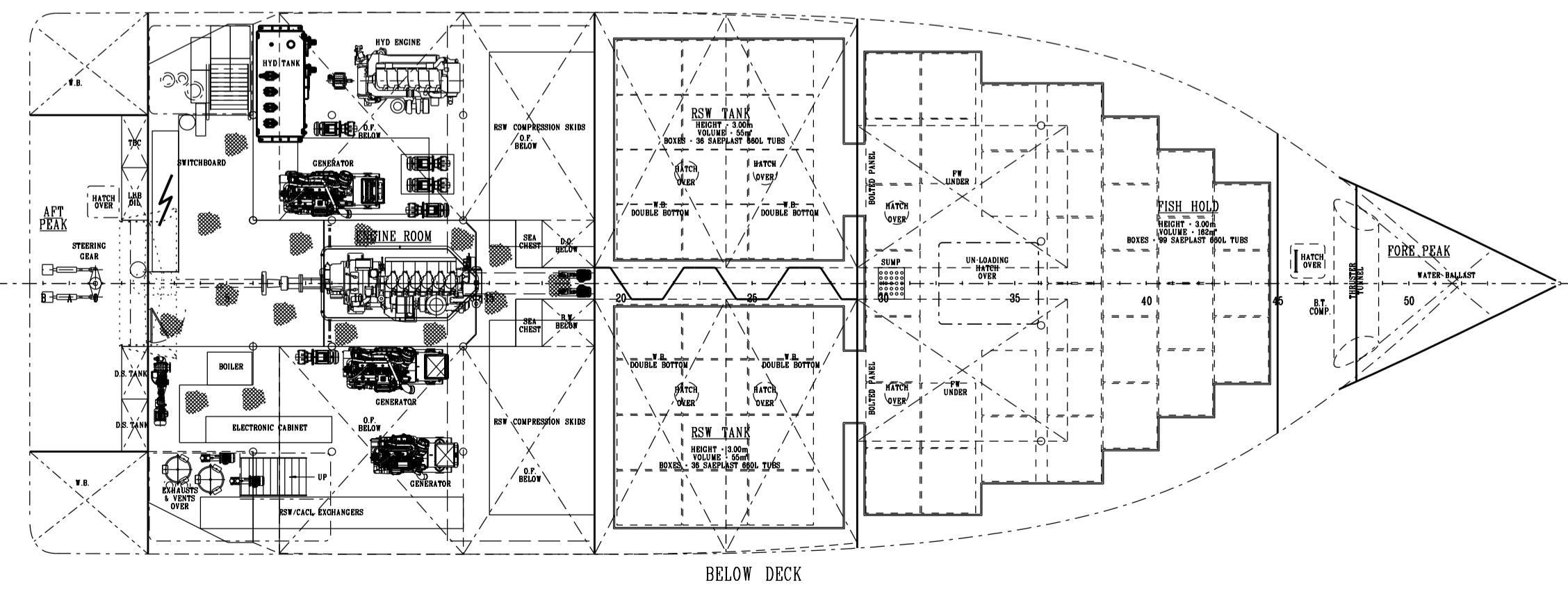
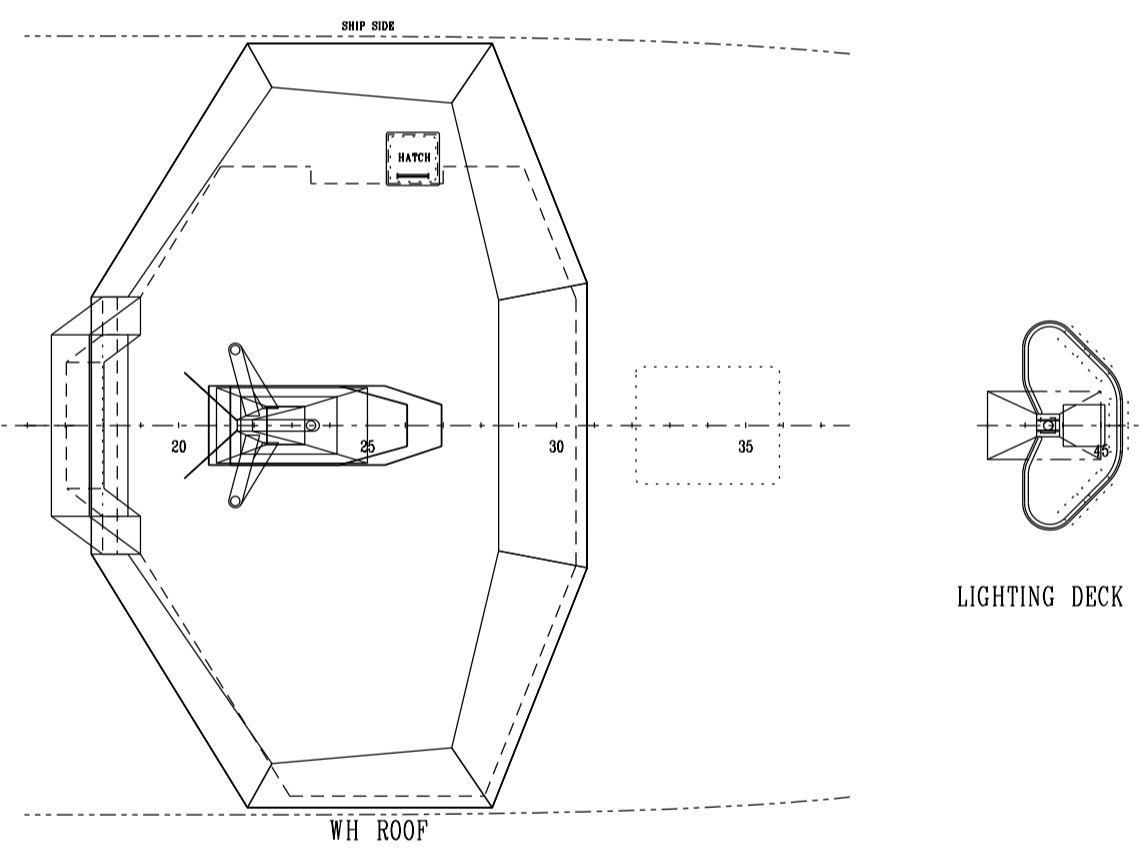
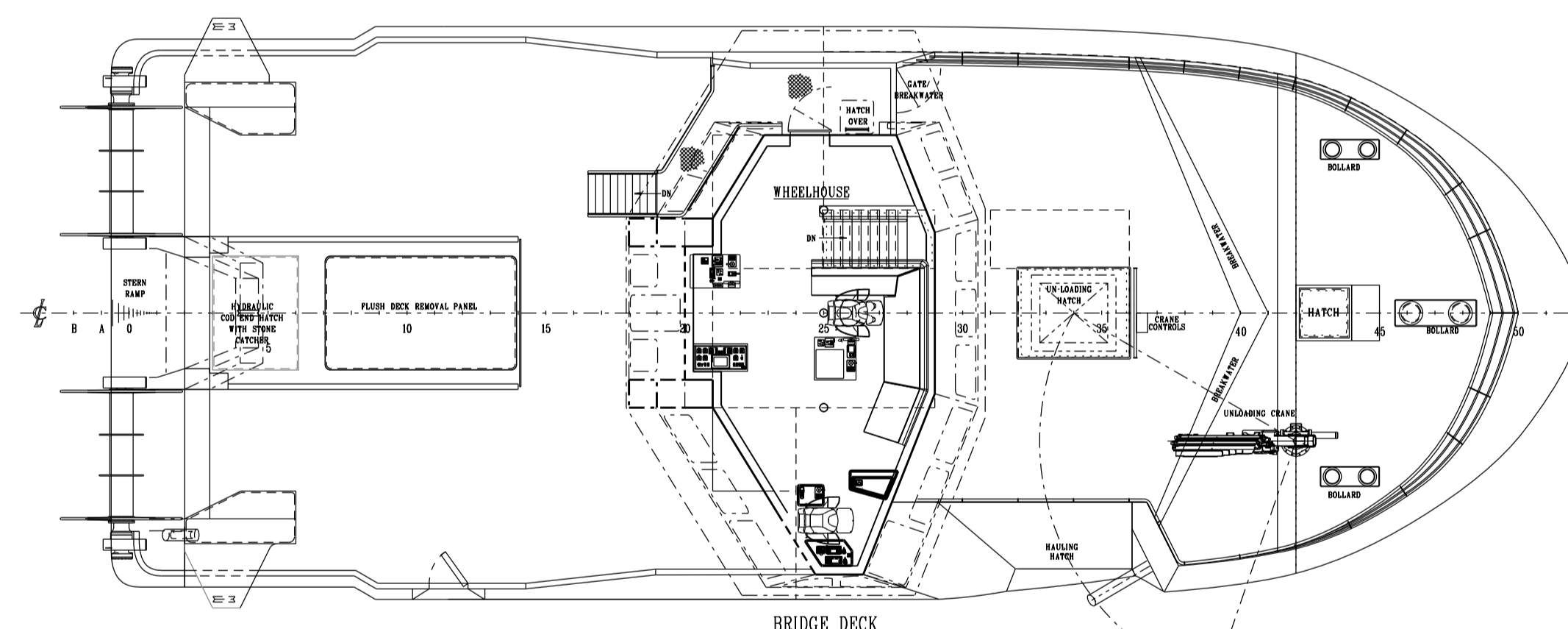
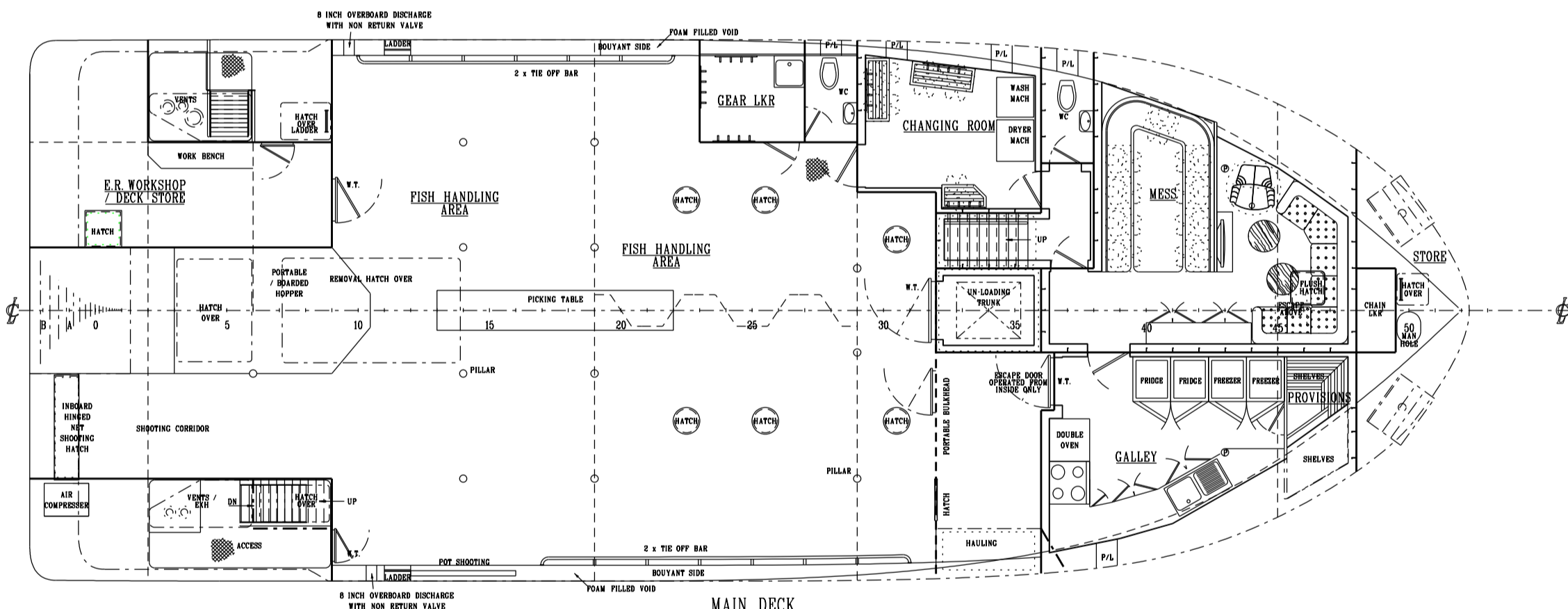
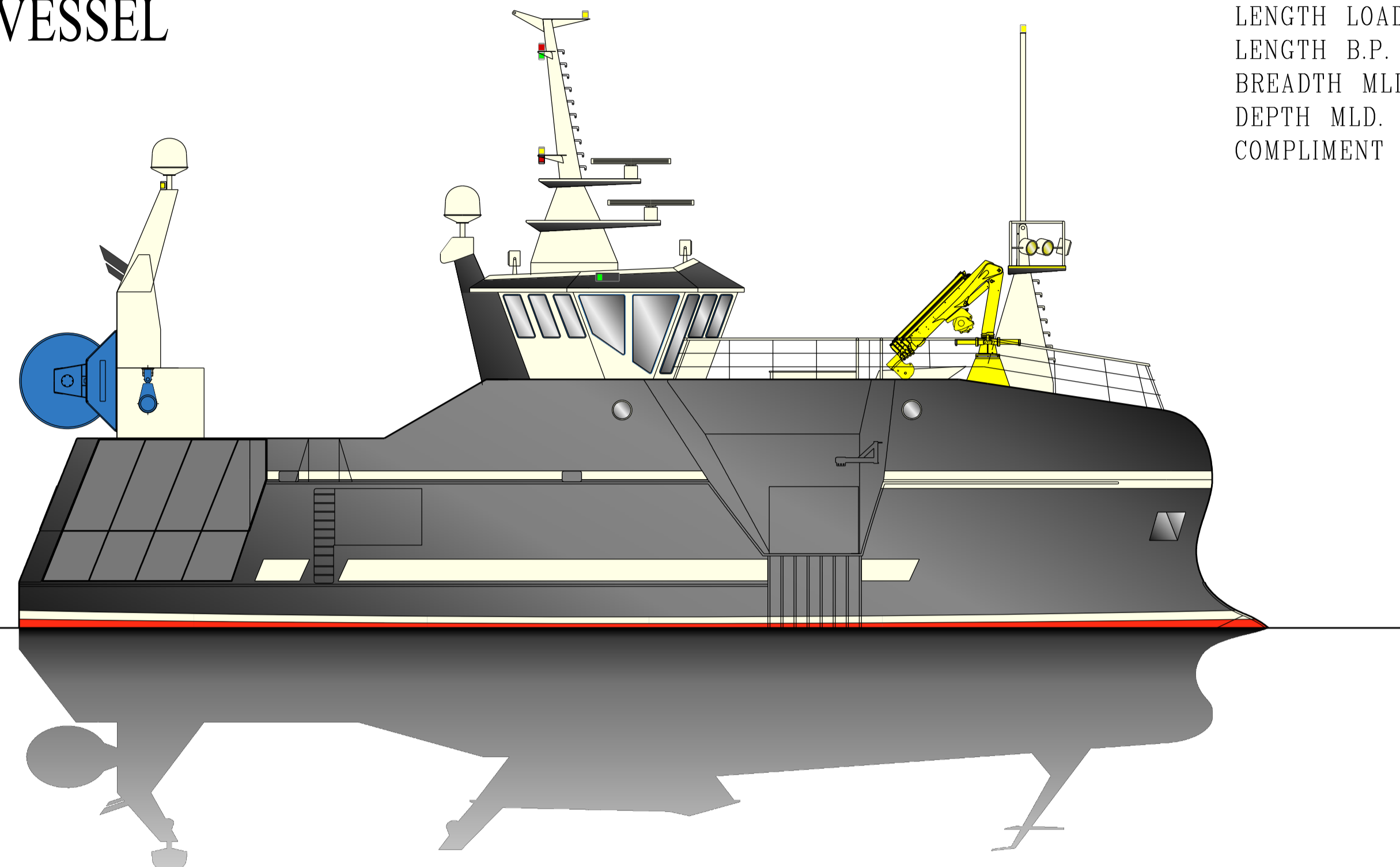
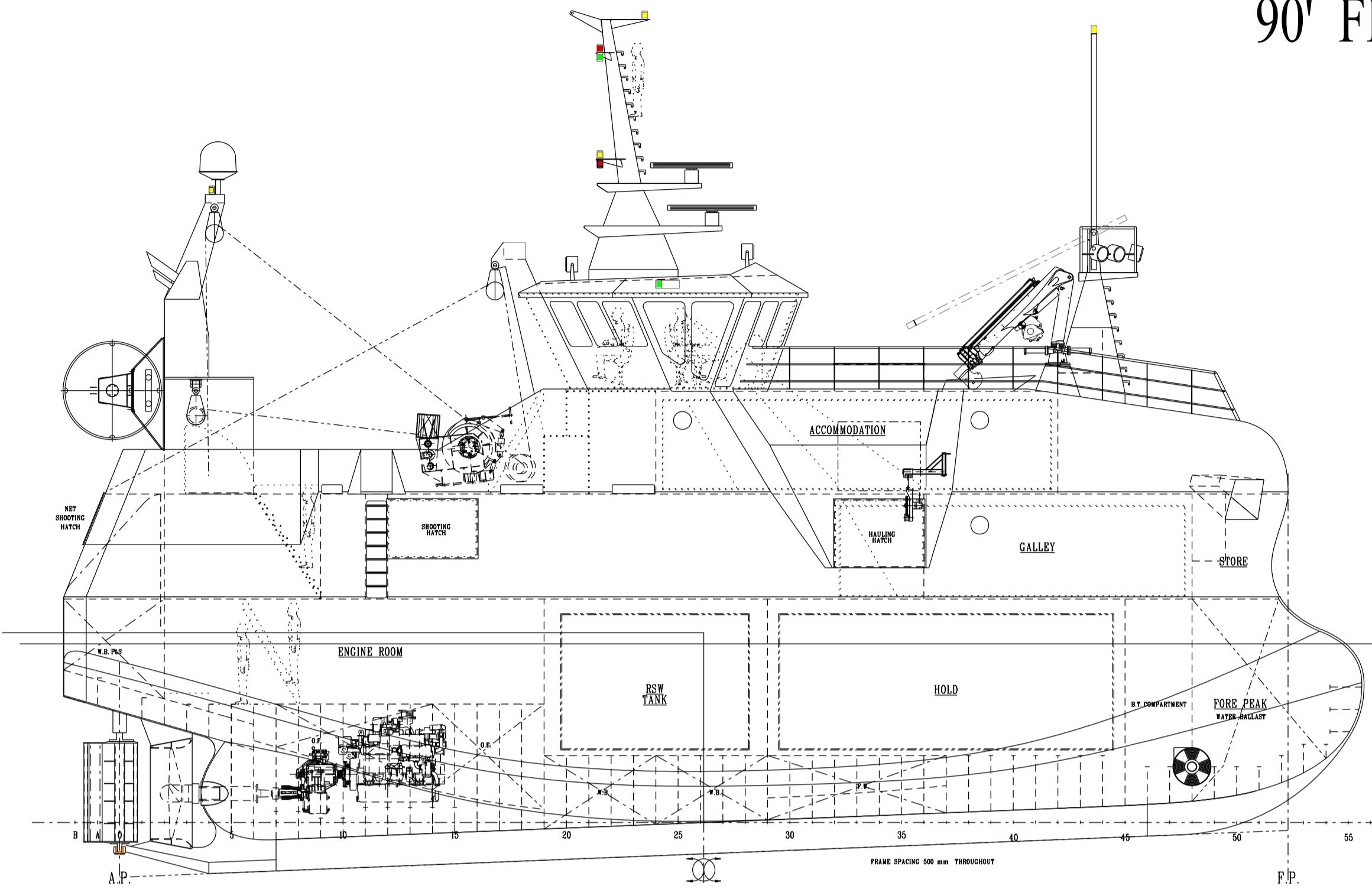

REV.	DESCRIPTION	BY	DATE	CHKD.	DATE
G	IN PROGRESS	DB	10/05/18	IAN	10/05/18
F	GENERAL UPDATES/ ER LAYOUT	DB	20/08/17	IAN	20/08/17
E	LENGTH UPDATED	DB	12/06/17	IAN	12/06/17
D	LENGTH UPDATED	DB	27/04/17	IAN	27/04/17
C	UPDATED TO SUIT STRUCTURAL ARRANGEMENT	DB	02/02/17	IAN	02/02/17
B	CONTRACT	JD	25/01/17	DB	25/01/17
A	CONTRACT	JD	12/01/17	DB	12/01/17
REV.	MODIFICATION	BY	DATE	CHKD.	DATE

APPROVED BY:-			
DATE:-			
TITLE:-	90' FISHING VESSEL GENERAL ARRANGEMENT	REP- YARD REF:- DRAWING NO :-	3378-1016 SBA01 01
DRAWN BY:-	MYLES	CHECKED BY:-	IAN
DATE:-	07-12-16	DATE:-	07-12-16
		REVISION :-	C
		SCALE:-	1:100 @ AI

THIS DRAWING AND THE INFORMATION IT CONTAINS ARE THE PROPERTY OF MACDUFF SHIP DESIGN LTD. IT IS NOT TO BE TRACED, COPIED OR PUBLISHED WITHOUT OUR WRITTEN CONSENT OR MISUSED IN ANY WAY.

MACDUFF SHIP DESIGN Ltd. LOW SHORE MACDUFF
ABERDEENSHIRE SCOTLAND AB44 1RE
TEL 01261 833825 FAX 01261 833835
EMAIL info@macduffshipdesign.com